

© TAIT ELECTRONICS
T800-52-0000
BACKPLANE

IPN: 220-01438-06	ISSUE: A	ID: 2.S.C. 1
PROJECT: T800	DESIGNER: SSAHI	FILE DATE: 143806a
		4-Jul-00

NO. SHEETS: 1

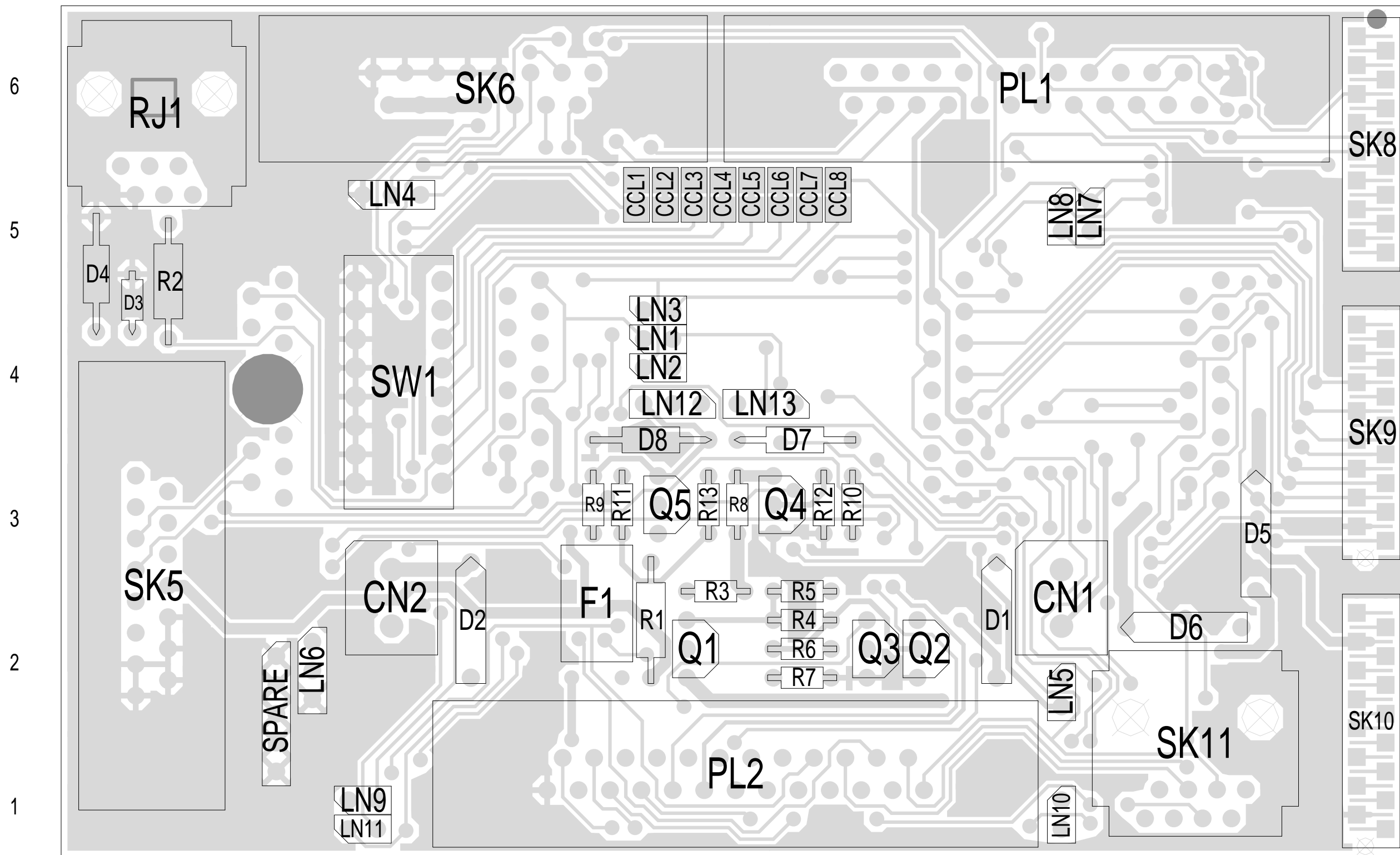

A

B

C

D

E

F

G

6

5

4

3

2

1

TAIT ELECTRONICS	IPN: 220-01438-06	ISS: A	ID: 1.TA	DATE: 4 Jul 2000
T800-52-0000 PCB LAYOUT - TOP SIDE				

Scale: 2.7:1 ; Rotation: 0 degrees

